

CAD FILE:

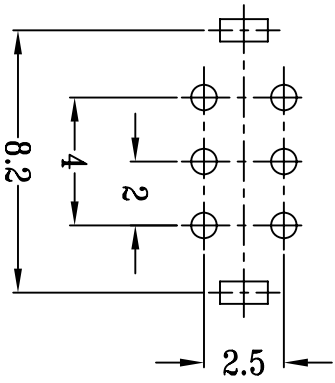

P.C.B LAYOUT

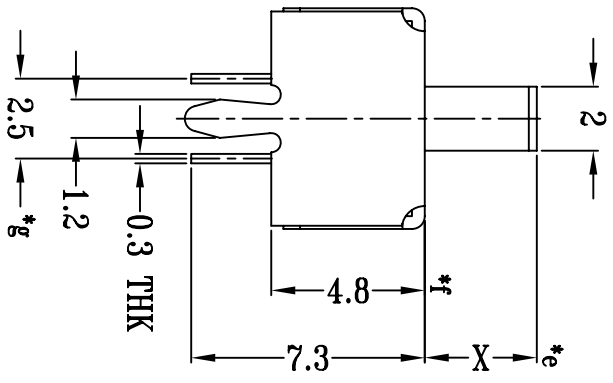
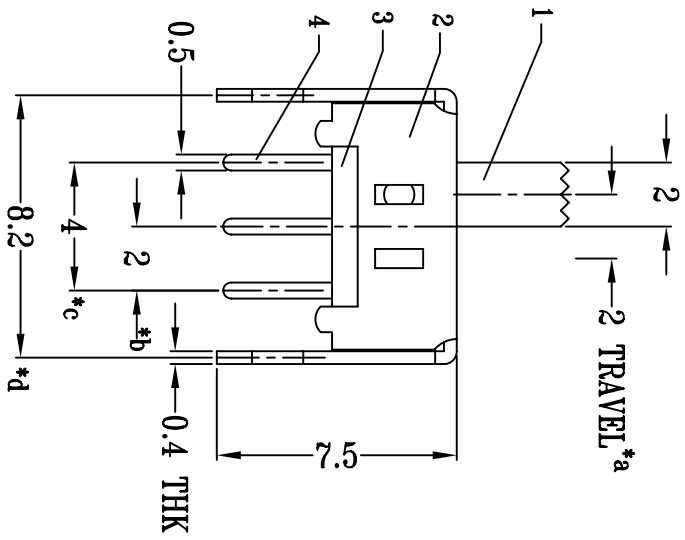
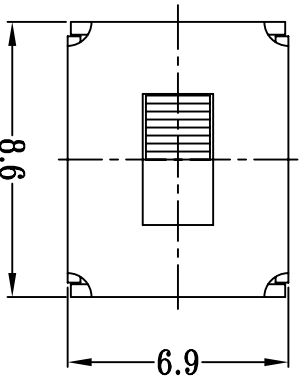
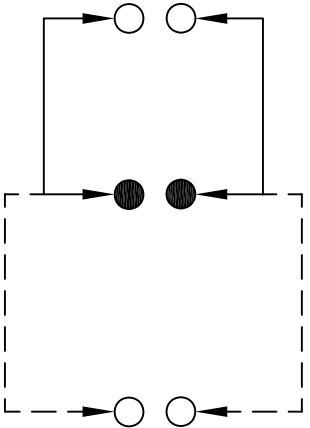

SCHEMATIC (NON-SHORTING)

注:带"\*"表示关键尺寸(7个)

8														
7														
6	SPRING PLATE	STAINLESS STEEL	2	NATURAL	TOLERANCE UNLESS SPECIFIED					SHENZHEN XIEJIA ELECTRONICS CO.,LTD.				
5	CONTACT CLIP	PBS	2	Ag CLAD										
4	TERMINAL	BRASS STRIP	6	Ag PLATED OVER Ni PLATED	WIDTH: 1.5±0.1mm OVER : 1.5±0.2mm	ISSUE	DATE	DESCRIPTIONS OF REVISION	APPD.					
3	BASE	PHENOLIC RESIN	1	NATURAL	TITLE : VERTICAL SLIDE SWITCH					UNIT : mm	SCALE: 4:1	DRWG NO.: XJ-DR-SS22D03-00		
2	FRAME	STEEL STRIP	1	Ni PLATED	MODEL: SS-22D03					DWN. ZHOUYU	2003-4-13			
1	KNOB	POM	1	BLACK	ALL MATERIALS MUST BE COMPLIANT TO ROHS					CHK'D FANGYING	2003-4-13			
NO.	PARTS	MATERIALS	Q'TY	FINISH						APPD. KANGMINAN	2003-4-13			